



GENERAL RULES:

1. The rules and regulations set forth herein do not guarantee safety, they are intended as a guideline for the safety of drivers within the said group, and are in no-way a guarantee against injury to participants or spectators
2. These rules and/or regulations will apply to all ILMS group events.
3. Group officials shall have full authority over group events and in the event of a dispute the series head official's decision will be final.
4. Group officials reserve the right to inspect any/all cars at anytime during a racing event.
5. Group reserves the right to confiscate any suspicious or illegal components.

MEMBERSHIP:

1. To be eligible for series points and/or contingency awards drivers MUST pay an annual membership fee of \$100.
2. Drivers may purchase a temporary membership for \$25 per event.
3. Internet bashing or negativity toward the group and or the members will not be tolerated, and may be grounds for membership to be revoked.
4. Membership monies are non refundable.
5. When becoming a member this entitles the group to use driver/team/owner name and stats/results whether + or - for publicity.
6. All drivers participating in ANY ILMS will pay \$10 inspection fee per event. The inspection fee MUST be paid prior to drawing for positions in any event. Refusal of any inspection is automatic disqualification.
7. All competitors must complete an Engine Release Form.

ENGINE RULES:

1. GM part number 19258602 & GM part number 19318604
*Items that can be changed to service engine are as follows:
Valve key GM part #12495503 #19301709
Valve cap GM part #19171528 #19301708
Valve spring GM part #12495494 #12625033
Valve spring seat GM part #19301707

*Any tampering with 1.5 rocker arms GM part #10241740
ARE GROUNDS FOR DISQUALIFICATION

*Any GM part #'s that are superceded by GM will be considered to be approved by series officials.
2. Engines must be sealed with GM bolts with GM square code etching on bolt, or with seals from approved series that all fall under the GM Technical Manual. Any engine is subject to be inspected as per the most recent GM Technical Manual for CT602 or CT604.

3. No changes are allowed to the engine-intake manifold, heads, valve covers, front timing cover, oil pan, harmonic balancer and any other part/parts on or within the engine.

* Any seals that appear to be tampered with or damaged will require engine to be re-inspected at teams cost to be considered legal.

(any certification or re-certification is at the cost of driver/team/owner)

4. No vacuum pumps.

5. Engine serial number must be clearly visible to series technical inspector.

6. Engine set back NOT to exceed six (6) inches from ball joint to number one (1) spark plug.

7. Any violation of the engine rules and/or factory specs inside the seals of the engine can result in the driver being disqualified from the event, the driver will forfeit all points and monies from event, and be suspended for remainder of season.

8. Group officials reserve the right to confiscate any parts deemed to be illegal for further inspection.

9. On site Engine inspection:

1. Valve spring pressure 100# seat pressure. Springs can be exchanged for further testing.

2. Compression test 180# maximum using the Group's inspection gauge.

3. 1.5 Rocker arm ratio, GM gauge

4. Cylinder pump @350cubic inches with group pump.

5. Vacuum 21 inch # tested with group gages @ 2000 RPM

6. The group reserves the right for officials to take engine for further inspection.

10. All decisions made by group officials are final!

CARBURETOR RULE:

1. One four-barrel carburetor only of any manufacturer.

2. No I.C.T. carburetors allowed.

3. Engine must be naturally aspirated.

4. 604-may use one carburetor spacer (1-inch piece with .040 tolerance maximum) and two standard paper gaskets (maximum 0.070 inch thick), one gasket between intake to spacer and one gasket between spacer to carburetor.

5. 602-may use one carburetor spacer (2 inch-one piece with .040 tolerance maximum) and two standard paper gaskets (maximum 0.070 inch thick), one gasket between intake to spacer and one gasket between spacer to carburetor.

6. Carb spacers must NOT protrude into carb or intake at any point.

DISTRIBUTOR RULE:

1. Any ignition with the exception of magnetos.

2. No traction control devices.

3. No 7AL boxes. (gold)

WATER PUMP RULE:

1. Cast or aluminum permitted. NO electric pumps allowed.

2. No electric fans. Fans MUST be driven by water pump. Four (4) blade steel fan only, minimum seventeen inches (17").

EXHAUST RULE:

1. Collector type headers required, they MUST have four (4) tubes into one (1) collector of a consistent diameter. Tri-y headers or merged headers, reversed coned, square tube or 180 degree headers are NOT allowed.

FUEL CELL/FUEL PUMP RULES:

1. An approved fuel cell (32 gallon max.) must be securely mounted in the trunk area of the car, inside a .20 gauge metal box supported by a minimum of two" (2) 1/8" steel straps.
2. No alcohol. No nitrous oxide.
3. Mechanical fuel pumps only.

TRANSMISSION RULES:

1. Must have at least one (1) forward and one (1) reverse gear in working order.
2. No straight drives or in and out boxes.
3. Drive shafts MUST be painted white. Carbon fiber drive shafts ARE legal.

BRAKE RULE:

1. No carbon fiber brakes.
2. No titanium brake rotors.

FRAME RULES:

1. All frames must be of steel construction.
2. Square or rectangular frame must have a minimum of 2" by 2" material, .083 wall thickness.
3. Round tube frame, tubing must have a minimum of 1-3/4" outside diameter, .083 wall thickness.

SHOCK RULES:

1. No Electronics of any kind attached or integrated to any shock at any time. No driver to shock adjustments.

ROLL CAGE RULES:

1. All cars must have a suitable steel roll cage protecting the driver's compartment, including headrest.
2. Side roll bars are mandatory, and must extend into the door panels. A minimum of three (3) bars must be on the left side.
3. Each bar must be at least 1-1/2" diameter, with a minimum thickness of .083".
4. Roll cages must be welded to frame.

WHEEL RULES:

1. Any brand or type of wheel allowed, but must be mounted with lug nuts.
2. No knock-off or center lock wheels.
3. Maximum wheel width 14".

WHEEL BASE:

1. Minimum wheel base is 103".

TIRE RULES:

1. LSB21, LSB55 or LM40 HOOSIERS ONLY for regular events. IIMS challenge races, tire rule MAY be altered to allow more tires, these changes will be noted when races are set. (Challenge races include but NOT limited to any races paying more than \$600 to win)
2. No covering of tires or compound numbers allowed at any time.

REAR ENDS:

1. No 8 inch ring & pinions or open tube rear ends allowed.

SAFETY RULES:

1. All cars must have at-least a four (4) point racing harness, NOT more than 3 years old and must have id tags attached to show manufacturing date.
2. All drivers MUST wear a complete fire suit.
3. Gloves are recommended, but not required.
4. Fire extinguishers are strongly recommended.
5. Raceceivers are REQUIRED ANY TIME DRIVER IS ON TRACK and MUST be in working order to participate in ANY event.

WEIGHT RULES:

1. GM crate engine #88958602 (602 engine) -2200 lbs. both pre and post race.
2. GM crate engine #88958604 (604 engine) -2350 lbs. both pre and post race.
3. Attached weight MUST be securely bolted to the frame with 1/2" or larger bolts (minimum of 2 bolts). Any weights lost during a racing event WILL be just cause for disqualification from said event. (MAKE SURE ALL WEIGHTS ARE SECURLY MOUNTED)
4. Added weights MUST be painted white and have car number displayed.
5. Track scales are the official scales used for that event.

PROTEST RULES:

*Any DRIVER wanting to protest a series competitor can do so as follows:

1. Driver must put up \$1500 cash to a series official prior to cars taking the track for a-main.
2. Protesting driver MUST be in the starting line up to proceed with protest.

*Protest monies will break down as follows:

\$500 to series inspector for pulling of motor, teardown, and inspection.

*In the event protested engine is found legal, driver will receive \$750 of monies put forth for protest.

*If protest motor is illegal, all illegal parts will be confiscated by series, and remainder of legal parts will be returned to rightful owner.

3. \$250 from ALL protest fees WILL go to driver point fund.
4. REMEMBER ONCE PROTEST MONIES ARE PAID TO A GROUP OFFICIAL, THE PROTEST WILL BE CARRIED THRU, REGARDLESS OF FINISH POSITION OF PROTESTED CAR.

BODY RULES:

1. No covering of cars allowed during an event, except for bad weather.

All body components 4" Min. above ground.

All body measurements are maximum unless otherwise specified.

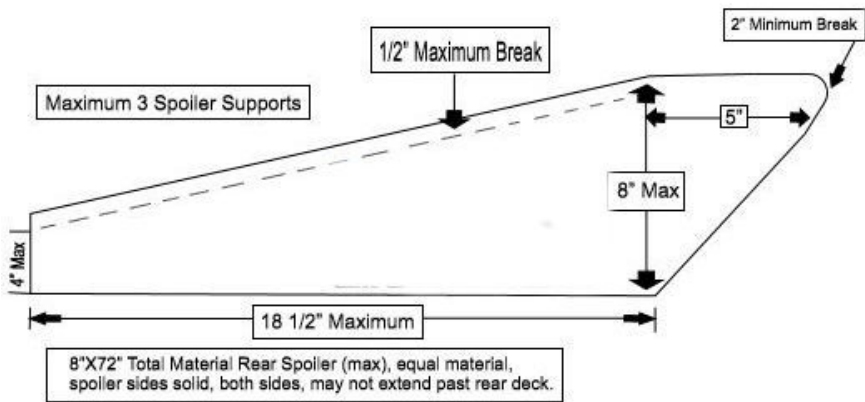
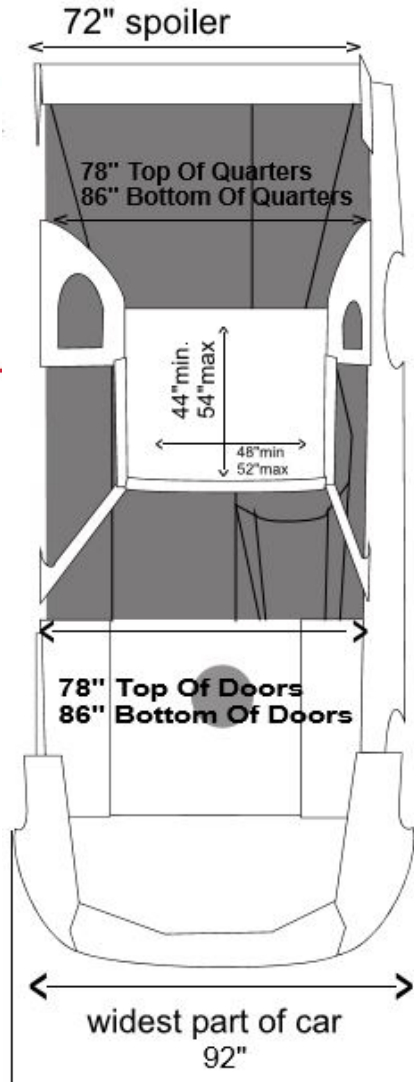
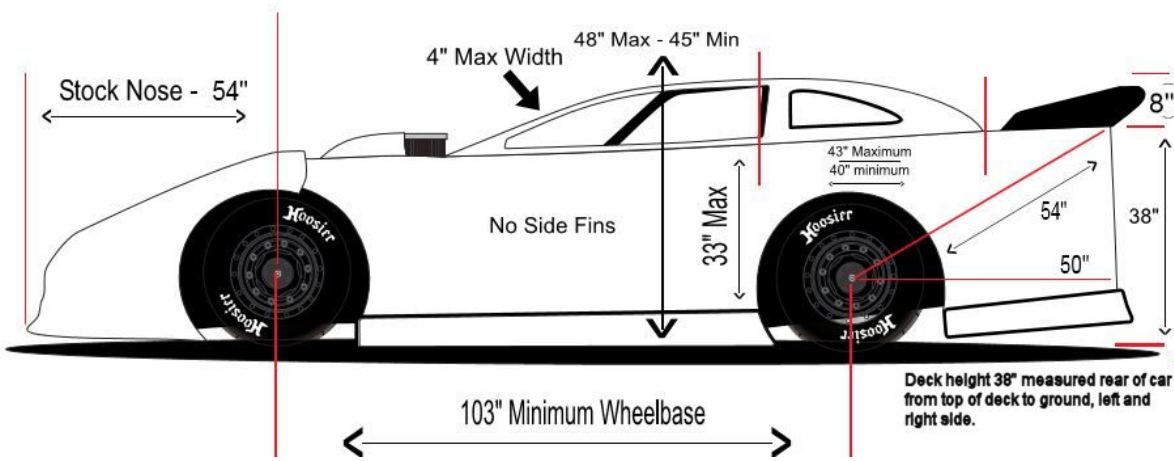

Roof Supports

ROOF SUPPORTS OR "C" PILLARS ON BOTH SIDES MUST BE MADE OF EQUAL MATERIAL. WINDOW OPENINGS ARE ALLOWED BUT MUST BE THE SAME SIZE OPENING ON LEFT AND RIGHT SIDE IF CLEAR LEXAN WINDOW IS USED IT MUST BE USED ON BOTH SIDES BOTH SIDES OPEN OR BOTH SIDES CLOSED. CURVED OR ARCED ROOF SUPPORTS ALLOWED, 3" MAXIMUM ARC ALLOWED AT WIDEST POINT, CHECKED WITH STRAIGHT EDGE, EXTENDED FROM ROOF EDGE TO DOOR EDGE.

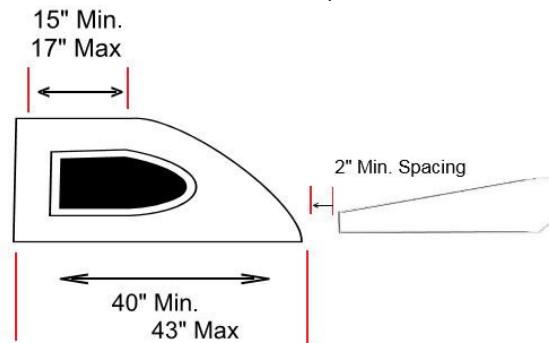
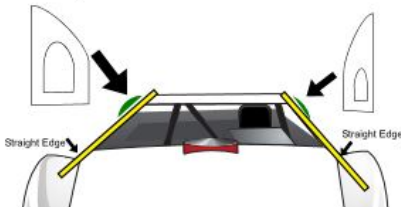

NOTICE TO ALL DRIVERS AND CAR OWNERS -

No equipment will be considered as having been approved by reason of having passed through tech inspection unobserved!

It is your responsibility to see that your car is legal. If you have any questions ask! All cars are subject to inspection at any time. There will be no admission or pit fee or entry fees returned if your car cannot run that night for whatever reason.

Remember, rules may not cover every incident that may occur. Therefore, in those situations the decision of the promoter and/or inspecting official is final. If you are asked to make changes to your car you must do so that night, please do not ask if you can run like it is. If your car is found illegal after a race, you forfeit all monies, trophies and points for that night.

All drivers are responsible for the actions of their pit crews. Any activity that is deemed to be poor conduct will result in the driver, pit crew member and car owner suspended for a time set forth by the officials and a fine may have to be paid before you are allowed to race again.

The rules and/or regulations set forth herein are designed to provide for the orderly conduct of racing events and to establish minimum acceptable requirements for such events. These rules shall govern the condition of all events and by participating in these events. All participants are deemed to have complied with these rules. No express or implied warranty of safety shall result from publication of/or compliance with these rules and/or regulations. They are intended as a guide for the conduct of the sport and are in no way a guarantee against injury or death to a participant, spectator or official.

The race official shall be empowered to permit minor deviation from any of the specifications herein or impose any further restrictions that in his opinion do not alter the minimum acceptable requirements. No expressed-or implied warranty of safety shall result from such alteration of specifications. Any interpretation or deviation of these rules is left to the discretion of the officials. Their decision is final.

If there is an issue in the tech area/scale area following an event, prize money for the top 5 positions will be held for one (1) week or until the next event, whichever ever comes first.

NOTE:

No alcoholic beverages or drugs allowed. Any driver under the influence of either or both of these faces immediate suspension from all activities concerning the Indiana Late Model Series (ILMS) for a period of time set forth by the promoter.

Revised 01-30-2019